

WARMTH OF HEARTH & HOME

DEFRO
home

operating manual

heating stove

DEFRO HOME ORION

**DEKLARACJA ZGODNOŚCI WE
DECLARATION OF CONFORMITY EC**

nr DH 11/P1/01/2022

DEFRO R. Dziubeła spółka komandytowa

26-067 Strawczyn, Ruda Strawczyńska 103A

DEKLARUJE / DECLARES

z pełną odpowiedzialnością, że produkt / *with all responsibility, that the product*

Wolnostojący ogrzewacz na drewno / Wood heating stove

DEFRO HOME ORION 6,7 kW

(typ/type DEFRO HOME ORION)

został zaprojektowany, wyprodukowany i wprowadzony na rynek zgodnie z następującymi dyrektywami:
has been designed, manufactured and placed on the market in conformity with directives:

**Rozporządzenie Parlamentu Europejskiego 305/2011 / Regulation of the European Parliament 305/2011
Dyrektywa ErP 2009/125/WE / Directive ErP 2009/125/WE**

**Rozporządzenie Delegowane Komisji (UE) 2015/1186 / Commission Delegated Regulations (EU) 2015/1186
Rozporządzenie Komisji (UE) 2015/1185 / Commission Regulation (EU) 2015/1185**

i niżej wymienionymi normami zharmonizowanymi:
and that the following relevant Standards:

PN-EN 13240:2008

dokumentacja techniczna / technical documentation

Wyrób oznaczono znakiem:
Product has been marked:



Ta deklaracja zgodności traci swą ważność, jeżeli w piecu wolnostojącym DEFRO HOME ORION wprowadzono zmiany, został przebudowany bez naszej zgody lub jest użytkowana niezgodnie z instrukcją obsługi. Niniejsza deklaracja musi być przekazana wraz z piecem wolnostojącym w przypadku odstąpienia własności innej osobie.

This Declaration of Conformity becomes invalid if any changes have been made to the DEFRO HOME ORION Dry Stove, if its construction has been changed without our permission or if the dry stove is used not in accordance with the operating manual. This Declaration shall be handed over to a new owner along with the title of ownership of the dry stove.

Wolnostojący ogrzewacz na drewno DEFRO HOME ORION jest wykonywany zgodnie z dokumentacją techniczną przechowywaną przez: DEFRO HOME ORION Wood heating stove has been manufactured according to technical documentation kept by: DEFRO R. Dziubeła spółka komandytowa, 26-067 Strawczyn, Ruda Strawczyńska 103a.

Imię i nazwisko osoby upoważnionej do przygotowania dokumentacji technicznej: Mariusz Dziubeła
*Name of the person authorized to compile the technical documentation: **Mariusz Dziubeła***

Imię i nazwisko oraz podpis osoby upoważnionej do sporządzenia deklaracji zgodności w imieniu producenta: Robert Dziubeła
*Name and signature of the person authorized to compile a declaration of conformity on behalf of the manufacturer: **Robert Dziubeła***

Dwie ostatnie cyfry roku, w którym oznakowanie zostało naniesione: 19
Two last digits of the year of marking: 19

Ruda Strawczyńska, 03.01.2022
*miejsce i data wystawienia
place and date of issue.*

Robert Dziubeła
prezes zarządu / CEO

Dear Customer,

We would like to inform you that we make every effort to offer the products of quality fulfilling the most restrictive standards and warranting operational safety. All the devices are produced in accordance with the requirements of relevant EU directives and have CE safety mark confirmed by the Declaration of Conformity EC.



We appreciate all your comments and proposals regarding our level of service. We appreciate your comments and proposals regarding our devices and the level of service provided by our Partners and Technical Support/Service.

DEFRO R. Dziubela sp.k.

Content of this Operating Manual is a property of DEFRO R. Dziubela sp.k.
Any copying, duplicating, publishing of the content of this Manual without prior written consent of DEFRO R. Dziubela sp.k. is forbidden.

Dear Customer,

We would like to thank you for choosing the high-quality DEFRO product which will ensure your safety and operational reliability.

As our customers, you can always count on the help of the DEFRO Service Centre, which is ready to ensure the continuous efficiency of your equipment.

Please note that in order to use the equipment safely and efficiently, it is crucial to get familiar with the following directions.

- Read and follow this Operating Manual - useful remarks concerning the proper operation of the equipment can be found there.
- Determine if all parts have been delivered or if the fireplace was not damaged during transport.
- Check the data on the rating plate against the warranty card.
- Prior to starting the device, check the flue connection against connection recommendations included in this manual and appropriate national regulations.

Basic usage rules are to be obeyed while using the equipment. Do not open the doors during the operation of the device.

DEFRO Service Centre or Authorized DEFRO Service should be always contacted when any intervention is necessary because only these parties have original spare parts and are properly trained within the scope of installation and operation of DEFRO equipment.

For your safety and equipment use convenience please get acquainted with this operating manual and send back a correctly filled copy of the Warranty Card to the following address:

 DEFRO R. Dziubela sp.k. - Centrum Serwisowe
Ruda Strawczyńska 103a
26-067 Strawczyn

 serwis@defro.pl

By sending back your Warranty Card, you will be registered in our DEFRO products users' database and we will be able to provide you with quick and professional technical support.

If you do not send back a correctly filled in Warranty Card and the equipment quality and completeness receipt within the period of up to two weeks after the date of installation but no longer than within six months, after purchasing, the warranty will become invalid. This results in delays with repairs and the necessity of **covering costs** of service and traveling expenses.

Thank you for understanding.
Yours sincerely,

DEFRO R. Dziubela sp.k.

Table of contents

1. INFORMATION	5
2. BASIC SAFETY RULES	5
2.1. Safety warnings	5
2.2. Warnings related to operation	6
3. INTENDED USE	6
4. TECHNICAL SPECIFICATION	6
4.1. Design	6
4.2. Technical data	6
4.3. Equipment	7
4.4. Fuel parameters	7
4.5. Spare parts	8
5. TRANSPORT AND INSTALLATION	8
5.1. Transport and storage	8
5.2. Working environment	8
5.3. Connection to external air intake	9
5.4. Installation to the flue	9
6. USAGE AND OPERATION	10
6.1. Introductory remarks	10
6.2. First start-up and operation	10
6.3. Damping	10
7. CLEANING AND MAINTENANCE	11
7.1. Basic operations and cleaning by the user	11
7.1.1. Cleaning before each starting	11
7.1.2. Window panel cleaning	11
7.1.3. Doors/gaskets	12
7.1.4. Furnace chamber	12
7.1.5. Flue	12
7.2. Periodic inspection by authorized service	12
7.3. Shutting the stove down	12
8. TROUBLESHOOTING	12
9. MEASURES IN THE CASE OF FIRE IN THE FLUE /SOOT IGNITION/	12
10. REMOVAL DUE TO WEAR-OUT	13
11. REMARKS ON DRY STOVE USAGE	13
12. PRODUCT WARRANTY TERMS AND CONDITIONS	13
12.1. Warranty conditions "48h Service"	14
13. WARRANTY CARD	17
14. CARRIED OUT WARRANTY REPAIRS AND MAINTENANCE	18
15. WARRANTY CARD (copy to send back)	19
16. COMPLAINT FORM	21
17. COMPLAINT FORM	23
18. COMPLAINT FORM	25
19. REGISTER OF INSPECTIONS OF SMOKE DUCT	26

1. INFORMATION

The operating manual is an integral and essential part of the product and must be forwarded to the user also in the case when the property is transmitted. The user should carefully read the manual and save it for the future because all remarks included there are important guidelines concerning safety during installation, usage and maintenance.

Installation of the stove must be carried out in accordance with the mandatory standards in the country of destination, according to guidelines of the manufacturer and by qualified personnel. Improper installation of the device may be a reason for personal injuries and damage to property for which the manufacturer is not liable.

The dry stove can be used only for the purpose it was explicitly intended. Any other use should be treated as inappropriate and in consequence as dangerous.

In the case of error during installation, usage or maintenance works caused by non-observance of the legislation, applicable regulations or instructions contained in this manual (or others, delivered by the manufacturer) the manufacturer rejects any contractual or non-contractual liability for resulting damages and the warranty for the device becomes void.

All illustrations, pictures and photos are only indicative.

Versions of the publication

Due to continuous improvement of the product, DEFRO reserves the right to update this publication without prior notice.

The content of this Operating Manual is a property of DEFRO. Any copying, duplicating, publishing of content of this User's Manual without the prior written consent of DEFRO is forbidden.

Manual storage and browsing of its contents

We recommend taking care of this manual and storing it in an easily and quickly available location. If this manual has been lost, damaged or destroyed you should request a copy in the sales outlet or directly from the Manufacturer providing identification data of the product. All the most important information included in the operating manual is marked with "bold" and has symbols pointing out the user's attention to hazards that can be present during the operation of the dry stove. The symbols used in the text are explained below:



Danger!

Direct threat to life and health! Non-compliance with the recommendations marked in this way and misuse may result in death or major injuries.



Danger!

Danger from electrical voltage! Incorrect installation and incorrect electrical connections may cause danger to life by electric shock.



Note!

Warning symbol indicating that you should read carefully and understand the given information, to which it relates. Non-compliance with those recommendations may result in major damage to the equipment and create a hazard for the user or the environment.



Danger!

Direct threat to health! Non-compliance with the recommendations distinguished in this way may cause a fire or burns.



Hint!

Informative symbol. Useful information and hints are marked in this way.

2. BASIC SAFETY RULES

2.1. SAFETY WARNINGS



- The national and local provisions should be met.
- The equipment should be installed in compliance with the legal standards applicable in the given location, region or country.
- The equipment should be used by persons (including children) with impaired physical, sensory, and mental capabilities and by persons without experience and required knowledge provided that such operation is not carried out under their supervision or after proper instruction by a person responsible for their safety.
- You should always observe the guidelines given in the operating manual to ensure the correct use of the equipment and to prevent accidents.
- Operation and adjustment should be carried out by adults. Errors and incorrect settings can cause hazardous situations and/or incorrect operation.
- Prior to any operations the user (or any person operating the equipment) should read and understand the whole contents of this manual.
- Equipment should be used only as intended. Each other use is considered as misuse and hazardous as a consequence.
- The equipment should not be used as a ladder or object to lean against.
- Prior to installation, you should make sure that the substrate will resist the force of the equipment considering its weight.
- In the case of disturbances in operation, the equipment can be restarted only when the occurred problem has been removed and the equipment is brought back to its original condition.
- The user is fully responsible for misuse of the product and relieves DEFRO from any civil and criminal liability.
- All types of modifications or replacement of equipment parts with non-original components or without authorization may present a risk for the operator and relieves DEFRO from any civil and criminal liability.
- Incorrect installation or maintenance (incompatible with the contents of this manual), can cause injuries to people, animals or property damage. Then DEFRO shall be relieved of any civil or criminal liability.
- Part of the equipment surface is very hot (doors, handle, window panel, flue gas discharge pipe, etc.). You should avoid direct contact with such components without suitable protective clothing or protective equipment such as e.g. heat-resistant gloves.
- Do not touch the window panel after heating up the equipment.
- Keep children away from the equipment when it is operating because each hot surface can cause burns.
- It is forbidden to start-up the equipment when the doors are opened or the window panel is cracked.
- Do not place and dry the underwear on the equipment. Possible dryers for hanging underwear or similar should be located at an adequate distance from the equipment - fire hazard.
- It is absolutely forbidden to open the doors if the flue is on fire. Then call the appropriate services.
- It is recommended to keep 400 mm distance between the hot parts of the equipment and medium inflammable materials; otherwise use commercially available insulation materials. Apply this hint also for furniture,



curtains etc. Minimum distances are given in point 5.2 of the operating manual.

- It is absolutely forbidden to use flammable liquid for equipment firing up.
- If the substrate, on which the equipment is located, is made of inflammable materials, such as parquet or floor lining then you should place protective plate under it (the plate should protrude 250-300 mm from the front of the equipment).

2.2. WARNINGS RELATED TO OPERATION



- Equipment should be shutdown in case of failure or incorrect operation.
- Fuel used in the equipment should meet the conditions described in this manual.
- Internal parts of the equipment should not be washed with water.
- Avoid contact with water; above all do not wash any painted surfaces until they are fully cured. The coating on new devices is not an anti-corrosion coating; heat-resistant paint achieves its protective properties only after curing under the influence of heat (after several ignitions).
- Do not expose the body to the action of hot air for a long period of time. Do not heat excessively the room where you are staying and where the equipment is installed. It may have an adverse impact on physical condition and be a reason for health problems.
- Equipment should be installed in rooms with fire protection and equipped with all required components such as supply (with air) and flue gas discharge.
- Equipment and cladding made of ceramics should be stored in rooms free from moisture and they cannot be exposed to adverse effects of the weather.
- It is not recommended to place the body of the equipment directly on the floor and if such floor is made of inflammable materials it should be properly insulated.
- To facilitate possible interventions by the technical personnel you should not place the equipment inside the closed rooms and just by the walls which can also disturb air intake.
- Always make sure and check whether the doors of the combustion chamber are tightly closed when the equipment is operating.
- Equipment consumes the exact amount of air that is required for the combustion process; it is recommended to connect the equipment for air intake from outside using a suitable pipe and through a special outlet located at the back of the equipment.

ADDITIONAL INFORMATION



- You should contact sales outlet or qualified personnel authorized by DEFRO in the case of any problems. Request original spare parts if the repair is necessary.
- Use only fuel with properties compatible with the recommendations of this operating manual.
- Check and clean flue gas discharge ducts (connecting piece to flue) periodically.
- Store this manual carefully because it should be available for a whole period of equipment operation. In the case of sale or giving the equipment to the other user you should always make sure whether the product has the manual enclosed.

4.2. TECHNICAL DATA

- Request a new copy from an authorized sales outlet in DEFRO company if it has been lost.

3. INTENDED USE

Dry stoves are intended for combustion of wood from deciduous trees. They are intended for heating of houses and spaces where they are installed. They can be also used as an additional source of thermal power.

Dry stove can be connected multiple times.

4. TECHNICAL SPECIFICATION

4.1. DESIGN

Dry stove operates as a heater for the room in which it is installed. Hot air is emitted directly from the furnace through the window panel and on by radiation through convection holes in the upper wall of the device.

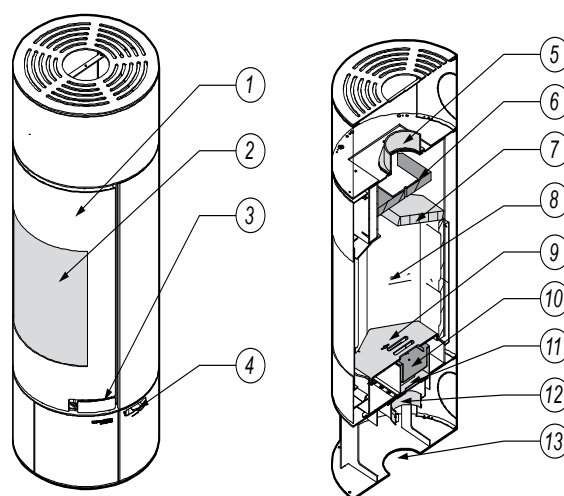

Picture 1. DEFRO HOME ORION dry stove design.

1 – doors with steel handle, 2 - window sheet of furnace, 3 - door handle, 4 - air inflow controllers: I – primary air inlet controller, II – secondary air inlet controller, 5 – flue Φ 146 mm, 6 – upper deflector, 7 – bottom deflector made of vermiculite, 8 – claddings of furnace chamber, 9 – grate, 10 – drawer for ash, 11 – adjustment of air inflow, 12 – air inlet socket (air intake) Φ 124 mm, 13 – bottom air supply opening.

The body of the dry stove - walls in contact with fire - is made of galvanized steel sheet and the furnace chamber is lined with ceramic cladding. The body is lined with panels made of steel sheet covered with powder paint.

Air for the combustion process is delivered through an air inlet opening (air intake) located under the combustion chamber; its quantity is controlled by a primary air controller marked with "I" symbol. The second controller, marked with "II", is intended for control of secondary air, flow of which around the glass window reduces its contamination during combustion. The primary air duct may be led by openings: in the rear panel or in base of the stove.

The socket for flue gas discharge is located in the upper wall of the stove.

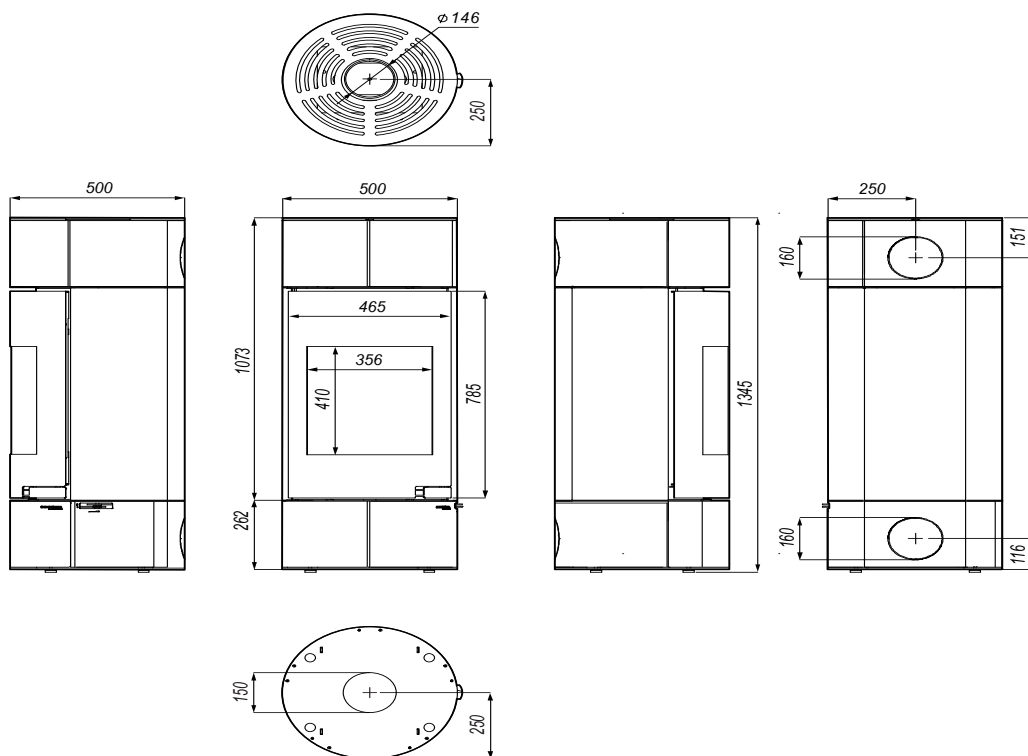

Picture 2. Dimensions of DEFRO HOME ORION dry stove (in mm).

Table 1.1 DEFRO HOME ORION dry stove technical data.

Parameter name	unit	value
Nominal power	kW	6.7
Flue size	mm	146
Diameter of air intake socket	mm	124
Efficiency	%	81.2
Seasonal energy efficiency	%	71
CO emission for 13% O ₂	%	0.06
Flue gas temperature	°C	244
Weight ¹⁾	kg	124 ± 5
Flue gas stream for nominal power	g/s	6.2
Minimum draught at rated power	Pa	12
Single fuel charging	kg	1.9
Average fuel consumption	kg/h	2.2
Fuel type	dry hardwood (max. 20% of moisture content)	
Type of heater	of periodic combustion	

¹⁾ Device weight depends on the selected design version and its equipment.

4.3. EQUIPMENT

Dry stove is delivered on a pallet, foil-wrapped and is fully assembled. Scope of delivery can include additional components and sub-assemblies, according to the order of the user. Components that are standard equipment are specified in table 2.

Table 2. Dry stove equipment.

Standard equipment of dry stove	unit	Quantity
Dry stove user's manual	pcs.	1
Ceramic lining of furnace chamber	set	1
DH sponge	pcs.	1

4.4. FUEL PARAMETERS

Dry stove is intended for the combustion of wood from deciduous trees (oak, hornbeam, ash, beech) with moisture content below 20% (wood seasoned in proper conditions for at least 2 years). The maximum length of chunks of wood is 300 mm.

It is not allowed to use wet wood (extensive contamination of fireplace and soot emission and decrease of energy efficiency of the stove).

It is forbidden to use all other fuels, min. coal, softwood from coniferous trees, wood from tropical trees and any liquid fuels.

It is forbidden to combust all types of litter and wood wastes. Firing with inadmissible materials in the fireplace may result in damage to the

fireplace and life and health hazard for the users (toxic flue gas from chemicals).



Use of bad quality fuel or incompatible with the above-mentioned recommendations would cause irregularities in the operation of the equipment and can lead to loss of warranty and decline of the liability for the product.

Dry stove is not intended for the combustion of wastes and forbidden fuels cannot be combusted in it.

Wood should be seasoned minimum of two (2) years. Firing with wet wood, with low calorific value, decreases the efficiency and has an adverse influence on dry stove lifetime.

It is not recommended to use softwood and resinous woods as fuel. It causes intensive smoke concentration and the necessity to clean the equipment and flue more often.



It is forbidden to combust coal, wood from tropical trees, chemical products, liquid fuels etc., e.g. oil, alcohol, petrol, naphthaline, laminated, impregnated boards etc., paper, cardboards, old clothes, wastes.

It is forbidden to exceed the declared amount of charged fuel, because it may cause overheating of the equipment.

DEFRO R. Dziubela sp.k. does not accept liability for damages caused or improper burning of fuel if the fuel used is prohibited.

4.5. SPARE PARTS

To obtain information on the availability of spare parts for dry stoves or inquiries about equipment servicing please contact with DEFRO Service Center or Authorized DEFRO Service.

	DEFRO R. Dziubela sp.k. Service Centre Ruda Strawczyńska 103a 26-067 Strawczyn		serwis@defro.pl
---	--	---	------------------------

5. TRANSPORT AND INSTALLATION

5.1. TRANSPORT AND STORAGE

Dry stove is delivered on a pallet, foil-wrapped and is fully assembled. It is recommended to transport dry stove, in such packing conditions, as close as the possible target location for installation, which will minimize the possibility of damage to the device housing.

All remaining parts of the packing should be removed in such a way that it will not pose any hazard to people and animals.

Appropriate lifts are to be used for lifting and lowering the dry stove. For transport, the dry stove is to be secured against moving and tilting on a vehicle's platform by means of belts, wedges and wooden blocks.



The dry stove is to be transported in a vertical position!

The dry stove is to be stored in a non-heated room, under a roof and with efficient ventilation.

Prior to installation, it should be determined if all parts have been delivered and if they are in good technical condition.

5.2. WORKING ENVIRONMENT



Dry stove should be installed in compliance with the requirements of the currently applicable standards and legal regulations and detailed regulations of the target country. In Poland these conditions are regulated by the Regulation of the Minister of Infrastructure of 12 April 2002 on technical conditions which should be fulfilled by buildings and its location. (Journal of Laws no. 75 of 2002 item 690 as amended) and Polish Standard PN-EN 13240:2008 Roomheaters fired by solid fuel. Requirements and tests.

Dry stove should be installed in a suitable location allowing opening of the doors and carrying out regular maintenance works. The environment should be:

- adapted to operating conditions,
- equipped with a power supply 230V/50Hz,
- equipped with a suitable flue gas exhaust system,
- equipped with an external ventilation system,
- equipped with an earthing system with a CE certificate.

Correct setting of the stove is necessary to obtain a satisfactory heating level of the residential unit. Prior to assembly, it is necessary to select a suitable position for stove installation. Check minimum safe distances from materials susceptible to heat or inflammable materials such as load-bearing walls and other walls or wooden components, furniture etc.

Installation of the dry stove should observe the following safety rules:

- minimum distance of 200 mm from the side and rear of the medium inflammable materials,
- minimum distance of 800 mm from the front wall, where the medium inflammable materials cannot be located.
- objects made of highly inflammable materials should be located at a distance minimum of 2000 mm from the furnace.

If it is not possible to maintain the above-indicated distances then you should apply process and building measures to avoid fire hazards. In the case of contact with wooden wall or wall made of other inflammable material, it is appropriate to insulate the flue gas discharge pipe.



In the case of floor made of inflammable materials, it is appropriate to prepare a plane protecting the floor and execute protection in accordance with the standards applicable in the given country.

Dry stove should be located on a substrate with suitable load-bearing capacity. In accordance with the Polish Standards, each square meter of the floor slab in a single-family building should transfer a load of 150 kg. If this condition is fulfilled the dry stove manufactured by DEFRO can be installed without needing to reinforce the floor slab.

Nonetheless, if you are not sure about the design of floor slab, where the stove is to be installed, you should absolutely contact the building designer to reinforce the floor slab or execute a special structure distributing the weight on a larger area.



Flooring in the room, where the stove is to be installed, should be properly dimensioned, to maintain the load.

To ensure the correct operation of the dry stove you should ensure the suitable inflow of air required for combustion (it is appropriate to ensure approx. 40 m³/h) in accordance with the installation standards and standards applicable in the given country. The volume of the surrounding environment should not be less than 30 m³. You should assume that the combustion of 1 kg of wood requires ~8 m³ of air.

Air should be supplied through fixed openings of a minimum 100 cm² cross-section made in the walls (near the stove) and directed to the outside. These openings should be made in a way ensuring that they cannot be plugged.

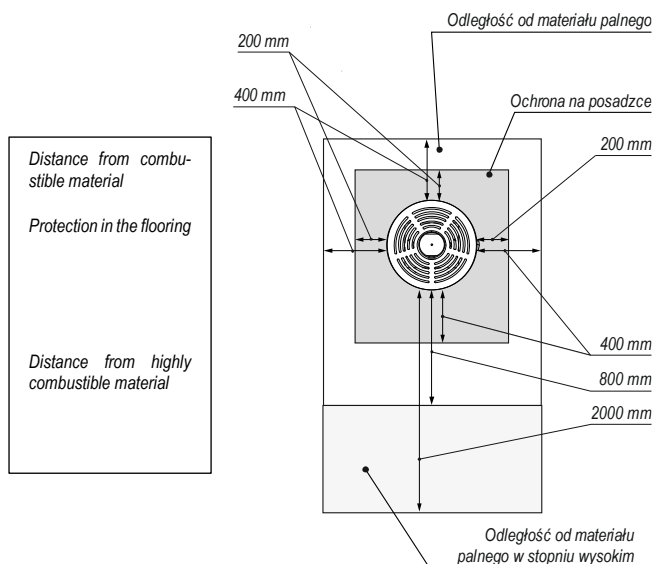

Figure 3.3 Minimum safe distances during setting of dry stove.

Air can be supplied from adjacent rooms, provided that they are equipped with external air supply and they are not intended for a bedroom and bathroom, and where fire hazard is not present, for example: garages, woodsheds, inflammable materials storage. You should absolutely observe the recommendations of the applicable standards.



It is forbidden to install dry stove in bedrooms, bathrooms and other rooms where other heating equipment without independent air inflow are installed (fireplace, stove, etc.).

It is also forbidden to set dry stove in explosive atmospheres.

5.3. CONNECTION TO EXTERNAL AIR INTAKE

Room, where the dry stove is installed, should be equipped with the inflow of air in the minimum amount required for the correct combustion process and for room ventilation. This can be done by executing fixed vents in the wall directed to the outside or through independent or common ventilation ducts.

The external wall near the stove should have through the opening with free cross-section of 100 cm² (opening with 12 cm in diameter or square 10 x 10 cm), protected with a grille on the internal and external side, for this purpose. Furthermore, the air intake should be:

- directly connected with the room, where the dry stove is to be installed,
- protected with grille, metal net or suitable cover not restricting minimum cross-section,
- located in a way preventing plugging it,
- located with consideration of proper distances preventing swirling of air (e.g. with respect to the windows).

DEFRO HOME ORION stove offers two versions of connection of external air inlet: from the back or bottom of the stove.

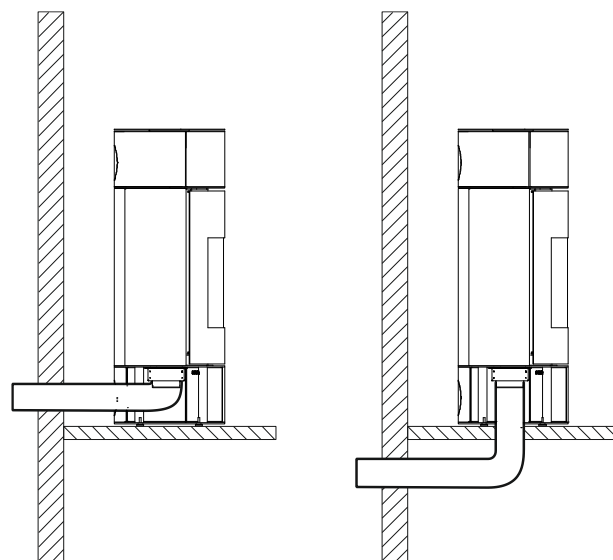

Picture 4.4 Connection of the DEFRO HOME ORION stove to the external air inlet.

5.4. INSTALLATION TO THE FLUE

Dry stove should be connected to an individual flue. The size of the chimney draught should equal:

- minimum draught – 6 ± 1 Pa,
- average, recommended draught – 12 ± 2 Pa,
- maximum draught – 15 ± 2 Pa.

During the execution of opening for flue gas discharge pipe you should consider the possible occurrence of inflammable materials. If the opening will pass through the wooden wall or wall made of material sensitive to heat then you should obligatorily maintain the minimum distance from flammable material (value given on the certification label of the pipe), with possible additional insulation using proper materials (thickness 1.3 - 5 cm, heat conductivity min. 0.07 W/m °K).

As an alternative it is recommended to use insulated industrial pipe, which can be also used outdoors, to avoid the occurrence of condensate.

For correct operation connector between the dry stove and flue or smoke duct should be executed acc. to the below recommendations:

- horizontal sections should have a minimum slope of 3% towards the top,
- length of the horizontal section should be minimum and should not exceed 2/3 meter,
- number of changes of directions, inclusive of the use of the "T" component, should not exceed 4.

A chimney or individual smoke duct should meet the following requirements:

- be resistant to combustion products, water-proof and suitably insulated, in compliance with conditions of use,
- be made of materials resistant to normal mechanical stresses, heat, the action of combustion products and possible condensate,
- be vertical with the change of axis direction not exceeding 45°,
- be adequately separated with void space or suitable insulation from combusted and inflammable materials,
- have preferably circular internal cross-section: square or rectangular cross-section should have rounded corners with a radius not smaller than 20 mm,
- internal cross-section should be constant, free and independent,
- have a rectangular cross-section with the maximum ratio between two sides equal to 1.5.



It is forbidden to use mechanical exhaust ventilation. The dry stove should not be used if the chimney draught is too low.

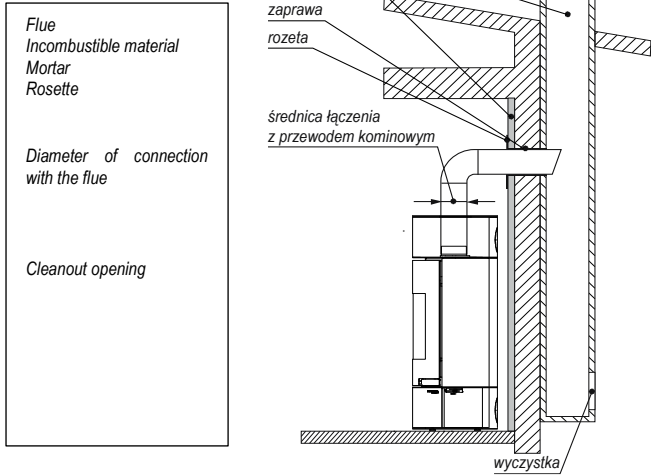

Picture 5 Option to connect DEFRO HOME ORION dry stove to the flue.

6. USAGE AND OPERATION

6.1. INTRODUCTORY REMARKS



Do not touch stove during the first firing-up, because the paint is hardening during this stage.

Touching the paint could result in uncovering of the steel surface.

It is possible to refresh it using spray paint of the same color if necessary.



It is a good practice to ensure efficient ventilation during first firing-up because small amounts of smoke and paint odor will be emitted from the stove.

Do not stay near the stove. It is required to vent the room. Smoke and paint odor will disappear after approx. one hour of operation. However, we remind them that they are not harmful to their health.

The stove is subject to expansion and shrinkage during the warming and cooling down stage which may cause slight squeaks. This is an absolutely normal phenomenon because the structure of the equipment is made of rolled steel and this phenomenon shall not be considered as a defect.

It is very important to avoid excessive overheating of the stove at the beginning but to reach the required temperature gradually. Use low heating powers. During the next firing-up of the stove, it will be possible to use the whole available thermal power. This will avoid damage to ceramic tiles, welds and steel structure.



Do not expect immediate effects of heating!

6.2. FIRST START-UP AND OPERATION

Firing from top is a recommended method of the firing of the dry stoves. Prior to firing up you should set a slider of air inflow adjustment to maximum opening (marking on the handle, presented in picture 6). Then open the doors of the stove and place fuel on the grate as follows: place split thick chunks at the bottom, then another layer of thinner

chunks. Place small slivers at the top, where you may additionally place eco-friendly kindling.

It is important to ensure free space (approx. 1 cm) between each of the chunks.

The single fuel charge is given in table 1.



It is forbidden to use other materials than described in this manual for firing up, in particular flammable chemicals such as: oil, petrol, solvents and others.

Maximum closing

maximum opening

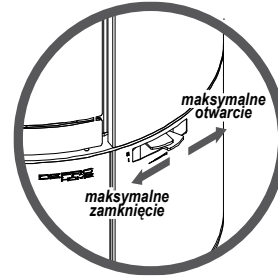

Picture 6 Adjustment of air inflow in DEFRO HOME ORION stove: upper controller controls the flow of secondary air, bottom controller controls the primary air.

You should use only hardwood (recommended beech, oak, hornbeam, birch), preferably debarked, of low moisture content (below 20%).

During combustion, the doors should be opened only when the fuel is being added. Recharging should be made only when only an ignition layer, in the form of glow, remains in the furnace. Before adding the wood, it is required to spread the remaining layer of glow and refill the combustion chamber with wood. The intensity of the combustion process should be set with the "air inflow adjustment slider". The correct flame should have a light-yellow color and a length of approx. 20-40 cm, depending on the power of the boiler, after approx. 2-3 minutes from charging. If there are problems to obtain the correct flame in a short time - you should increase the opening of a flow damper and set the target position after firing up.



Never stand in front of the stove door while opening it. Burn risk.

The odor of paint from the body will be released during the first several hours of combustion. This is completely normal. You should strongly vent the room at that time. Check the tightness of joints once again when fuel is completely burned out and equipment has been cooled down.



Housing components will be very hot during operation. You must exercise caution.

Empty the ash drawer prior to each successive start-up of the equipment. Remove grate, then ash drawer using handles, and remove the remaining dust. The window panel should also be cleaned. Do not use sharp materials. It will damage the surface of the window panel and screen printing.

6.3. DAMPING

Damping is executed by the closing inflow of primary air. In such a case you should wait until the fuel completely burns out in a natural way.

If it is necessary to quickly damp a flame you should charge the furnace chamber with dry sand or ash. It is not allowed to dampen a flame by pouring it with water because it may damage components of the equipment.



After a longer break in equipment's operation, you should check the flow capacity of the flue.

7. CLEANING AND MAINTENANCE



All operations related to the cleaning of all components should be carried out when the stove is completely cold. It is required to use protective gloves.

It is forbidden to clean the equipment (all painted components and gaskets) using chemicals, liquids and moist cloths, towels, industrial wipers etc. Discolorations, sources of corrosion may occur if the mentioned rules are not observed and they are not covered by the warranty.



It is a good practice to ensure good ventilation of the room during the cleaning of the fireplace.

7.1. BASIC OPERATIONS AND CLEANING BY THE USER.



Any service and maintenance works are to be carried out with meticulous care and only by adults familiarized with this manual. The dry stove should not be cleaned in the presence of children.

7.1.1. CLEANING BEFORE EACH STARTING

Prior to every successive start-up of the equipment, the ash container should be cleaned and emptied, handling the ash with due care. Remove grate, then ash container using handles, and remove the remaining dust. Dust can be removed using a vacuum cleaner only if it is completely cold. Use a vacuum cleaner adapted to removing the particles of specified size for this purpose.

Re-install the ash container below the grate after the cleaning, making sure that its position is correct.

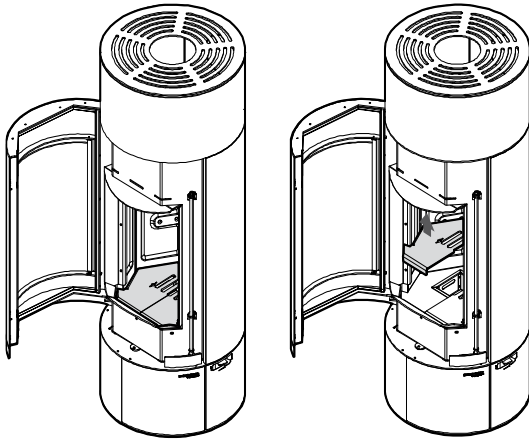

Open the doors and lift one of two parts of the grate.

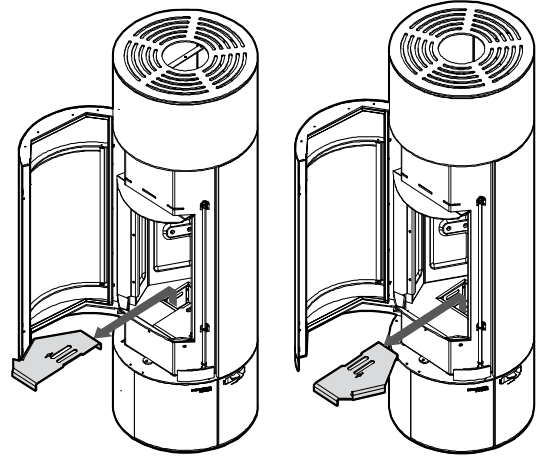

First, remove the first part of the grate, then remove the other one.

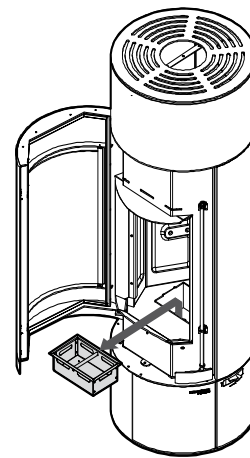

Lift and remove the ash pan.

7.1.2. WINDOW PANEL CLEANING

The window panel may be cleaned only and exclusively when the fireplace does not operate and is at room temperature.

Before each cleaning of the glass pane, it is required to protect the painted components and surfaces, and gaskets against flooding, because it has an impact of quicker wear and tear of the components.

We recommend using only the DH sponge to clean the glass panes. We do not recommend using any liquid for cleaning of glass panes or chemicals. The absence of protection of the cords surrounding the glass panes causes loss of their properties, soaking with chemicals and reactions with high temperature that results in damage to the glass pane.

The sponge is intended only to clean the glass panes, it should not be used for gaskets or metal parts. It is not suitable for cleaning of glass panes with pyrolysis. The sponge may be used several times, depending on the degree of soiling of the glass pane. Use the gray side for cleaning and brush it off each time after use.

Do not use products that may scratch the glass pane. The ash may contain substances that will scratch the glass ceramics.



It is forbidden to use abrasive agents or materials, because they may scratch the glass surface.

It is forbidden to use chemical cleaning agents, because in the case of contact with such agents they may cause damage to the components of the stove, that is print on the glass pane, glass pane, gaskets, and painted surfaces.



Do not open doors to clean the window panel during the operation of the fireplace. Cleaning of window panel is possible only when the equipment is cold.

7.1.3. DOORS/GASKETS

Abrasive surfaces of doors and closing mechanisms should be occasionally lubricated with graphite grease. Carry out inspection and cleaning of whole stove prior to each heating season. Pay special attention to the condition of gaskets, and replace them if necessary.

7.1.4. FURNACE CHAMBER

Clean the furnace chamber of the stove periodically, depending on moisture content and type of wood used.

7.1.5. FLUE

In compliance with applicable regulations, you should clean the flue twice (2) a year. The flue should be cleaned by a chimney sweep company and this fact should be documented in this manual.



Flue gases coming out of the blocked chimney are dangerous. Chimney and connector should be kept clean. They should be cleaned before each heating season.



After a longer break in equipment's operation you should check the flow capacity of the flue.

7.2. PERIODIC INSPECTION BY AUTHORIZED SERVICE

After the heating season it is necessary to clean the chamber through which flue gas is flowing. This cleaning is obligatory and is intended to remove all combustion residues.



Periodic inspection of the equipment should be carried out only by qualified manufacturer's service.

7.3. SHUTTING THE STOVE DOWN

It is recommended completely shutdown the stove and clean the equipment when each heating season is finished.

8. TROUBLESHOOTING

Some anomalies indicating irregularities in operation can occur during operation of the equipment. It can be caused by incorrect installation of the equipment without observation of the applicable building regulations or provisions of this manual or by external causes e.g. natural environment.

Below you will find the most frequent causes of incorrect operation of the equipment with their solutions.

Smoke draw back when the doors are opened:

- too rapid opening of the doors (open the doors slowly);
- if a chimney damper has been installed as a chimney draught regulator - open the chimney damper each time when the doors are opened;
- insufficient air inflow to the room, where the equipment is installed (ensure proper ventilation in the room or supply air to the combustion chamber in compliance with guidelines in the manual);
- atmospheric conditions: low pressure, mists and precipitation, sharp changes in temperature;
- insufficient chimney draught (carry out chimney sweep inspection of the flue).

Insufficient heating or damping:

- too low amount of fuel in a furnace (charge furnace in compliance with the manual);
- too high moisture content of wood used for combustion (use wood with moisture content <20%) a large part of obtained energy lost in water evaporation process;
- too low chimney draught (carry out chimneysweep inspection of the flue).

Insufficient heating despite good combustion in combustion chamber:

- low calorific "soft" wood (use wood as recommended in the manual);
- too high moisture content of wood used for combustion (use wood with moisture content <20%);
- too fragmented wood, too thick chunks of wood:

Excessive contamination of window panel:

- low intensity of combustion (combustion with very small flame, use only dry wood as fuel);
- using resinous softwood as a fuel (use dry hardwood as a fuel foreseen in the stove operating manual).

The correct operation can be disturbed by atmospheric conditions (air moisture content, fog, wind, atmospheric pressure) and sometimes by closely located high facilities.

In case of repeated problems, you should turn to chimneysweep company to confirm the reason for such a condition and to indicate the best solution for the problem.

9. MEASURES IN THE CASE OF FIRE IN THE FLUE /SOOT IGNITION/.



Systematic cleaning of smoke ducts should be performed to prevent soot ignition in the chimney.

Soot ignition in the chimney is the burning of particles deposited inside the chimney (flue) channels; the deposits are formed in the course of heating equipment's operation and were not cleaned by chimney sweeps. In a case of soot fire in chimney the following recommendations should be observed:

- call Fire Brigade at 998 or 112, give information about what is happening and give detailed directions what is happening and how to get to the given building;
- damp a fire in chimney by the closing inflow of cold air to the furnace chamber;
- close stove's door and cleaning holes tightly to cut off air supply (due to lack of air the fire will eventually stop);
- check the whole chimney channel for any cracks which might result in fire spreading to the rooms;
- prepare fire quenching means, e.g. a fire extinguisher, a fire blanket, a hose connected to the water system, water in a container;
- make rooms and necessary information available to the Fire Brigade.



It is strictly forbidden to pour water into the chimney - risk of blowout.

Tight chimney channels can be a source of burning sparks or very hot flue gas, including insensible carbon monoxide.



Chimneysweep should be called after soot fire in the chimney to perform cleaning of ducts and to inspect their technical condition.

10. REMOVAL DUE TO WEAR-OUT

Dry stove is made of materials neutral to the environment. After worn out of the stove parts connected with screws should be disassembled by unscrewing and welded parts must be cut. Elements of a stove are subject to standard waste disposal, mostly as steel scrap. Take safety precautions during disassembly of the equipment by using appropriate hand-held and mechanical devices as well as personal protective equipment (gloves, clothes, apron, glasses, etc.).

11. REMARKS ON DRY STOVE USAGE.



The following rules for the safe operation of the dry stoves should be strictly observed and introduced.

- 1) The dry stove can be used only by adults, who have familiarised themselves with this operating manual and have been trained in the scope of usage.
- 2) It is forbidden for children to be in the neighborhood of the stove without adults.
- 3) Flammable liquids must not be used for torching the fuel; only solid fuel (e.g. tourist), paper can be used etc.
- 4) Flammable materials must not be placed on the stove and in its vicinity.
- 5) It is forbidden to damp a fire in a furnace with water.
- 6) It is forbidden to use stove with a cracked window panel.
- 7) You should use fuel recommended by the manufacturer.
- 8) Never stand in front of the stove door while opening. Burn risk.
- 9) While removing ash from the stove, flammable materials cannot be located closer than 1500 mm from the stove. Ash is to be put into heat-resistant containers with a lid.
- 10) After the heating season has finished, the stove and smoke channel are to be precisely cleaned.
- 11) Point corrosion spots are allowed because they do not impact the correct operation of the equipment and do not reduce its performance. They may occur as a result of incorrect storage of equipment (e.g. in rooms of high moisture content).
- 12) A phenomenon of condensation of water steam - condensate, may occur during operation.

12. PRODUCT WARRANTY TERMS AND CONDITIONS

- 1) Placing warranty statement, which contents correspond to the provisions of this document, the Guarantor - manufacturer of the product - DEFRO R. Dziubela spółka komandytowa, Ruda Strawczyńska 103 A, 26-067 Strawczyn, entered in the Register of Entrepreneurs of the National Court Register by the District Court for the capital city of Warsaw XII Commercial Division of the National Court Register, under the number KRS 0000620901, NIP: 9591968493, National Business Registry Number [REGON]: 363378898, gives the Purchaser a warranty for the sold product on the terms and conditions specified below.
- 2) The guarantee refers to a dry stove type with serial number (subject of agreement - dry stove) under the condition that the product has been fully paid. Due to suitable, proven and unified standards of sales the warranty covers only products purchased at authorized points of sales of the Guarantor or from authorized distributors. Full list of authorized companies is available on the website www.defro.pl.
- 3) When the whole price will be paid and the product will be issued to the user also the warranty card will be issued. In the warranty card is missing the Purchaser should immediately contact with the Seller to obtain this document, while its lack has no influence on the validity and period of the warranty given based on this statement, it can have an influence on the correct, timely processing of obligations resulting from this warranty by the Guarantor.

- 4) To allow Guarantor efficient operation the Purchaser should immediately after issuance of the product, send back a copy of a correctly completed Warranty Card to the address of the Guarantor (Ruda Strawczyńska 103a, 26-067 Strawczyn). The correctly filled Warranty Card has date, stamp and signatures in designated locations.
- 5) The Purchaser receives Warranty Terms and Conditions, Warranty Card as well as Operating Manual containing conditions for boiler's usage, installation guide and parameters regarding the chimney, fuel and boiler water.
- 6) The Guarantor guarantees that the equipment works correctly provided that all conditions specified in the Operating Manual have been met, especially with respect to parameters applying to fuel, and connection to chimney system. The warranty covers the product used in compliance with its intended use and information provided in the service manual. A guarantor is not responsible for the effect of normal wear and tear of the product which is connected with operation.
- 7) The warranty authorizations period commences on the date of issuance of the product to the Purchaser and equals:
 - a) 5 years for the correct operation of the equipment,
 - b) 2 years for claddings made of heat-resisting concrete - Ceramiton, while the warranty does not cover discolorations, a complete change of the color or degradation of the top layer of the coating.
 - c) 1 year for grate, deflector and gaskets of the fireplace,
 - d) elements subject to wear-out are not covered by the Warranty; these include: ceramic hardened glass, screws, nuts, handles etc.
- 8) The Warranty is valid in the Republic of Poland.
- 9) During the warranty period, the Guarantor ensures free-of-charge repairs of any physical defects of the product within the period of:
 - a) 14 days after the fault report, unless the repair requires replacement of constructions elements of the product;
 - b) 30 days after the fault report, if the repair requires replacement of constructions elements of the product;
 - c) subject to point 3 and 4 of these warranty conditions.
- 10) If, as a result of considering the warranty claim the defective product has been replaced with a new one or the significant repairs have been made, then a new warranty period is applied counting from the date of delivery of the replaced or repaired product. In case when only part, belonging to the claimed product, is replaced then a new warranty period is applied only for this part. In the other cases, the warranty period is prolonged by a period when the operation of the product was impossible due to filed claim.
- 11) Registration of any physical fault to be repaired during the warranty period (fault registration) should be made by the Purchaser immediately after a fault has been found and no later than after 14 days.
- 12) Any fault is to be registered with the Guarantor (Ruda Strawczyńska 103a, 26-067 Strawczyn) by sending a complaint sheet contained in this operating manual, filled in and stamped by an authorized point of sale or authorized distributor. The fault registration should contain:
 - a) type, capacity, serial number, manufacturer number (the information is located on the rating plate),
 - b) date and place of purchase,
 - c) brief description of the fault,
 - d) detailed address and phone number of the Purchaser.If the following cases are complained about: incorrect combustion in the device, tar deposits, smoking through the door; the fault registration should be supplemented with a copy of a chimney sweep expertise certifying that the flue meets all requirements specified in the operating manual for a given boiler's capacity.
- 13) The Guarantor shall not be responsible for exceeding of the periods mentioned in point 9 above or the Guarantor or its representatives will be ready to remove the defect within the date agreed

- with the Purchaser and will not be able to carry it out due to reasons not attributable to the Guarantor (e.g. lack of proper access to devices, lack of energy or water, force majeure, Purchaser is not present etc.).
- 14) If the Guarantor, despite being ready to carry out the repair, will not be able to carry out the warranty repair twice because of the reasons attributable to the Purchaser then it is assumed that Purchaser had resigned from the claim included in the guarantee claim. Notification about the same defect in this mode is not possible.
 - 15) The product can be replaced if the Guarantor decides it cannot be repaired.
 - 16) The Guarantor does not accept liability for inappropriate choice of product with respect to the heated area (e.g. device of too low or too high power with respect to requirements). It is recommended to choose a device with cooperation with a design office or the Guarantor. The Guarantor is not liable for loss of data saved in the equipment and for economical losses and lost profits.
 - 17) The Guarantor will refuse realization of Purchaser's claims resulting from this document in the case when:
 - a) will state damage or ripping of leaden seals,
 - b) identification of product will be impossible (that is conformity of the presented product with a document describing the equipment, replaced or illegible documents),
 - c) damages resulting from incorrect transport carried out or ordered by Purchaser,
 - d) particular components of the equipment were willfully replaced with non-genuine, used etc., repairs outside the authorized service of the Guarantor etc.
 - e) damages are mechanical, chemical, thermal and they are not resulting from causes in the sold product.
 - f) damages concerns wearing parts, especially: screws, nuts, handles, ceramic and sealing elements,
 - g) damages resulting from product usage inconsistently with the operating manual, that is especially when incorrect equipment operation resulting from lack of chimney draught or inappropriate power of the equipment,
 - h) Faults are not significant and do not have an impact on the use value of the product.
 - 18) This warranty does not cover:
 - a) products used for business purposes or industrial uses;
 - b) components of electrical equipment;
 - c) damages caused by the other connected equipment, devices or accessories other than those recommended by the Guarantor.
 - d) damages occurred as a result action of external impacts, among other: by the action of force majeure;
 - e) damages caused by the animals,
 - f) damages resulting from overheating of the equipment that is: discoloration of a glass pane, "milky discolorations", discoloration of metal components, "rainbow steel", blue discolorations, chipping of paint, gasket discolorations, deformation of steel components.
 - 19) Warranty repairs accepted by the Guarantor are carried out free of charge. The guarantor can charge the costs connected with the warranty claim only in the case when claim is not accepted as a result of stating circumstances which are listed in points 17 and 18 mentioned above.
 - 20) Notification of complaint can be considered positively only in the case of:
 - a) keeping the time-limits mentioned in this document;
 - b) fulfilling the other terms and the conditions of the warranty;
 - c) presentation of product proof of purchase - that is invoice or fiscal receipt, the other proof of purchase, in compliance with the regulations;
 - 21) Device installation can be carried out by a person holding general installation qualifications but an entry and stamp in the Warranty Card is required.
 - 22) Device's first start-up, any repairs and other activities, which are not supposed to be carried out by the User according to the operating manual, can be carried out only by an authorized service trained by the Guarantor. The device's first start-up is payable by the Purchaser.
 - 23) During the execution of the warranty repair, the customer is responsible for securing the location of repair, including the system of fireplace insert, adjacent floor, walls etc. If the repair requires removing the housing, then the user is responsible for such removal. Signing the complaint form, indicates that the customer does not have any remarks related to the condition of the equipment's surroundings, including the condition of the system, floor, walls etc. after completion of the repair.
 - 24) Warranty repair is made in the location when the product is operated. If the claim applies to part of the product, including electronic equipment /electronic controller, fan etc. then the given part should be sent to the Guarantor at his expense. Returning faulty equipment is a condition to accept the claim and replace this equipment for free. Not returning the above-mentioned part within seven (7) working days will be subject to not accepting the claim and charging its costs to the purchaser.
 - 25) Provisions of this document do not limit in any way authorizations resulting from the claim submitted on the basis of statutory warranty. The warranty also had no influence on the other claims of the Purchaser, according to the provisions of law - including these concerning non-conformity of the goods with the contract. The purchaser can exercise powers from the statutory warranty regardless of powers resulting from the guarantee. If the purchaser exercises his powers resulting from the warranty, the period for execution of powers resulting from the warranty will be suspended from the date of notice about the defect. This period will be continued from the date of refusal by the Guarantor about the execution of obligations resulting from the warranty or ineffective lapse of time for their execution.
 - 26) To all matters not settled in this Warranty Card and document the provisions of the Civil Code Art. 577 - 581 shall apply.

12.1. WARRANTY CONDITIONS "48H SERVICE"

- 1) The "48h Service" program covers the heating equipment manufactured by DEFRO R. Dziubela sp. k.
- 2) Any complaints are to be made at a retail outlet, directly at the Company's e-mail: serwis@defro.pl, or by a letter to the company's address.
- 3) Fault registration can be completed if the Purchaser has a purchase confirmation and has filled in the Warranty Card correctly including a complaint sheet.
- 4) The "48h service" ensures that DEFRO R. Dziubela sp. k. does its best to remove any faults which make it impossible/difficult for the equipment to operate within the period of two business days from the day of fault registration.
- 5) Fault removal time may be prolonged for reasons not dependent on DEFRO R. Dziubela sp. k., such as the necessity of replacement of construction elements, lack of spare parts at the supplier, adverse weather conditions /force majeure/.
- 6) Failure to carry out repairs within this period cannot constitute a ground for any claims against DEFRO R. Dziubela sp. k. and Authorized Service Partner.
- 7) To facilitate contact with service, service hotline for Customers has been set up: 509 702 720 and 509 577 900. If you call on these numbers, you will receive the necessary information and help with any service issue.

We kindly inform that the possible replacement of the equipment component, with the working one, claimed by the user is not unambiguous with the admission of equipment user's warranty claims and does not end the complaint processing procedure. DEFRO reserves the right to charge the equipment's user with component replacement/repair costs, which after expertise/repair was stated as damaged by the factors independent of the boiler's manufacturer (e.g. short-circuit in the electric system, overvoltage,

flooding, mechanical damages not visible to the naked eye etc.) and which damages were not able to stated during repairing in the location of equipment operation by the service, within 60 days from date of carrying out the repair. DEFRO will issue an appropriate invoice for replacement/repair of the subject component with the enclosed expertise protocol. At the same time we inform, that lack of payment for the invoice including the above-mentioned costs within 14 days from its issuance results in irrevocable loss of warranty for the used equipment and this information will be entered into our computer supervision system for equipment within the warranty period. The date when the due amount is credited to the bank account given in the mentioned invoice is treated as the payment date.

WARRANTY CARD

Confirmation of equipment's quality and completeness

In accordance with the conditions stated herein, a warranty for a stove

DEFRO HOME ORION type.....operated in accordance with the operating manual, has been issued.

Equipment manufacturing number*

Equipment power* kW

User (name and surname)**

Address /street, city, postal code/**

tel./fax** e-mail**

Sale date

Installation date

Start-up date

.....
(stamp and signature of salesperson)

.....
(stamp and signature of salesperson)

.....
(stamp and signature of company starting up
the dry stove)

The user confirms that:

- the equipment has been delivered as complete;
- the device showed no failure during the first start-up carried out by a service company,
- has received the Operating Manual and equipment's installation manual with this Warranty Card filled in;
- has been familiarised with equipment's operation and maintenance.

.....
city and data

.....
user signature

* filled by the manufacturer

** filled by the user

The Customer and the installation and service company confirm by their own signature that their personal data can be processed for service register purposes according to the art. 6 section 1, letter a of the General Data Protection Regulation of 27 April 2016 (OJ EU L 119, 04.05.2016).

DEFRO R. Dziubeła spółka komandytowa
• 26-067 Strawczyn, Ruda Strawczyńska 103A • tel. 041 303 80 85 • biuro@defro.pl • www.defro.pl •

14. CARRIED OUT WARRANTY REPAIRS AND MAINTENANCE.

No.	date	fault description, repaired element, description of repairs	comments	Stamp and signature of Service
1.				
2.				
3.				
4.				
5.				
6.				
7.				
8.				
9.				
10				



WARRANTY CARD

Confirmation of equipment's quality and completeness

In accordance with the conditions stated herein, the warranty for a stove:

DEFRO HOME ORION type operated in accordance with the operating manual, has been issued.

Equipment manufacturing number*

Equipment power* kW

User (name and surname)**

Address /street, city, postal code/**

.....

tel./fax** e-mail**

Sale date

Installation date

Start-up date

.....

.....

.....

(stamp and signature of salesperson)

(stamp and signature of salesperson)

(stamp and signature of company starting up the dry stove)

The user confirms that:

- the equipment has been delivered as complete;
- the device showed no failure during the first start-up carried out by a service company,
- has received the Operating Manual and equipment's installation manual with this Warranty Card filled in;
- has been familiarised with equipment's operation and maintenance.

.....
city and data

.....
user signature

* filled by the manufacturer

** filled by the user

The Customer and the installation and service company confirm by their own signature that their personal data can be processed for service register purposes according to the art. 6 section 1, letter a of the General Data Protection Regulation of 27 April 2016 (OJ EU L 119, 04.05.2016).

DEFRO R. Dziubela spółka komandytowa
• 26-067 Strawczyn, Ruda Strawczyńska 103A • tel. 041 303 80 85 • biuro@defro.pl • www.defro.pl •



COMPLAINT FORM

made on..... in connection with complaint no.

SUBJECT OF COMPLAINT

EQUIPMENT TYPE: Equipment manufacturing date:
Equipment serial no.: Equipment purchase date:

CLAIMANT

Name and surname:
Detailed address:

Phone number

DETAILED DESCRIPTION OF QUALITY FAULTS OR FAULTS RESULTING FROM THE MANUFACTURER'S FAULT

.....
.....
.....

OTHER FAULTS

CLAIMANT LODGES WARRANTY CLAIM FOR (SELECT APPROPRIATE):

Warranty repair Paid repair Post-warranty paid repair

CLAIMANT REQUESTS.....

In the case when a claim is not taken into consideration because circumstances, mentioned in p. 17 and 18 of the Warranty Terms are discovered, the CLAIMANT agrees to cover the costs incurred by the manufacturer's service.

.....
(city and data) (sign of claimant) (signature of serviceman)

FAULT REMOVAL - to be filled by service

Date of informing the service technician about faulthour
Name and surname of service technician
Way of fault removal

Advice (DESCRIPTION)

END OF COMPLAINT

Name and surname of service technician: Fault removal date:

Justness of complaint: Duration of repair:

*Fault (defect) has been removed, the equipment operates correctly. I hereby confirm the removal of the fault. I declare that I have familiarised myself with the conditions of the warranty on the basis of which I wish to register my complaint.
The Customer and the installation and service company confirm by their own signature that their personal data can be processed for service register purposes according to the art. 6 section 1, letter a of the General Data Protection Regulation of 27 April 2016 (EU L 119, 04.05.2016).*

.....
(city and data) (sign of claimant) (signature of serviceman)

ATTENTION! In the case when a claim is not taken into consideration because circumstances, mentioned in p. 17 and 18 of the Warranty Terms are discovered, the CLAIMANT agrees to cover the costs incurred by the manufacturer's service.*
*cost per man-hour and traveling expenses are calculated according to the current price list available at www.defro.pl.



COMPLAINT FORM

made on in connection with complaint no.....

SUBJECT OF COMPLAINT

EQUIPMENT TYPE: Equipment manufacturing date:
Equipment serial no.: Equipment purchase date:

CLAIMANT

Name and surname:
Detailed address:

Phone number:

DETAILED DESCRIPTION OF QUALITY FAULTS OR FAULTS RESULTING FROM THE MANUFACTURER'S FAULT

.....
.....
.....

OTHER FAULTS

CLAIMANT LODGES WARRANTY CLAIM FOR (SELECT APPROPRIATE):

Warranty repair Paid repair Post-warranty paid repair

CLAIMANT REQUESTS.....

In the case when a claim is not taken into consideration because circumstances, mentioned in p. 17 and 18 of the Warranty Terms are discovered, the CLAIMANT agrees to cover the costs incurred by the manufacturer's service.

..... (city and data) (sign of claimant) (signature of serviceman)

FAULT REMOVAL - to be filled by service

Date of informing the service technician about faulthour

Name and surname of service technician

Way of fault removal

Advice (DESCRIPTION)

END OF COMPLAINT

Name and surname of service technician: Fault removal date:

Justness of complaint: Duration of repair:

*Fault (defect) has been removed, the equipment operates correctly. I hereby confirm the removal of the fault. I declare that I have familiarised myself with the conditions of the warranty on the basis of which I wish to register my complaint.
The Customer and the installation and service company confirm by their own signature that their personal data can be processed for service register purposes according to the art. 6 section 1, letter a of the General Data Protection Regulation of 27 April 2016 (EU L 119, 04.05.2016).*

..... (city and data) (sign of claimant) (signature of serviceman)

ATTENTION! In the case when a claim is not taken into consideration because circumstances, mentioned in p. 17 and 18 of the Warranty Terms are discovered, the CLAIMANT agrees to cover the costs incurred by the manufacturer's service.*
*cost per man-hour and traveling expenses are calculated according to the current price list available at www.defro.pl.



COMPLAINT FORM

made on in connection with complaint no.

SUBJECT OF COMPLAINT

EQUIPMENT TYPE: Equipment manufacturing date:
Equipment serial no.: Equipment purchase date:

CLAIMANT

Name and surname:
Detailed address:

Phone number:

DETAILED DESCRIPTION OF QUALITY FAULTS OR FAULTS RESULTING FROM THE MANUFACTURER'S FAULT

.....
.....
.....

OTHER FAULTS

CLAIMANT LODGES WARRANTY CLAIM FOR (SELECT APPROPRIATE):

Warranty repair Paid repair Post-warranty paid repair

CLAIMANT REQUESTS

In the case when a claim is not taken into consideration because circumstances, mentioned in p. 17 and 18 of the Warranty Terms are discovered, the CLAIMANT agrees to cover the costs incurred by the manufacturer's service.

..... (city and data) (sign of claimant) (signature of serviceman)

FAULT REMOVAL - to be filled by service

Date of informing the service technician about fault hour

Name and surname of service technician

Way of fault removal

Advice (DESCRIPTION)

END OF COMPLAINT

Name and surname of service technician: Fault removal date:

Justness of complaint: Duration of repair:

*Fault (defect) has been removed, the equipment operates correctly. I hereby confirm the removal of the fault. I declare that I have familiarised myself with the conditions of the warranty on the basis of which I wish to register my complaint.
The Customer and the installation and service company confirm by their own signature that their personal data can be processed for service register purposes according to the art. 6 section 1, letter a of the General Data Protection Regulation of 27 April 2016 (EU L 119, 04.05.2016).*

..... (city and data) (sign of claimant) (signature of serviceman)

ATTENTION! In the case when a claim is not taken into consideration because circumstances, mentioned in p. 17 and 18 of the Warranty Terms are discovered, the CLAIMANT agrees to cover the costs incurred by the manufacturer's service.*
*cost per man-hour and traveling expenses are calculated according to the current price list available at www.defro.pl.

19. REGISTER OF INSPECTIONS OF SMOKE DUCT

date	stamp and signature of chimneysweep	date	stamp and signature of chimneysweep

PRODUCT SHEET

**in accordance with the Commission Regulation 2015/1185
on the execution of the Directive of the European Parliament and the Council 2009/125/EC**

Equipment parameters

Model identifier(s): DEFRO HOME ORION, DEFRO HOME OMI, DEFRO HOME OPAL

Indirect heating functionality: [yes/no]

Direct heat output: 6,7 (kW)

Indirect heat output: N/A (kW)

Fuel	Preferred fuel (only one):	Other suitable fuel(s):	η^s [%]:	Space heating emissions at nominal heat output				Space heating emissions at minimum heat output			
				PM	OGC	CO	NO _x	PM	OGC	CO	NO _x
				mg/Nm ³ (13 % O ₂)				mg/Nm ³ (13 % O ₂)			
Wood logs with moisture content ≤ 25 %	yes	no	71	40	120	1500	200	n/a	n/a	n/a	n/a
Compressed wood with moisture content < 12 %	no	no									
Other woody biomass	no	no									
Non-wooden biomass	no	no									
Anthracite and dry steam coal	no	no									
Hard coke	no	no									
Low temperature coke	no	no									
Bituminous coal	no	no									
Lignite briquettes	no	no									
Peat briquettes	no	no									
Blended fossil fuel briquettes	no	no									
Other fossil fuel	no	no									
Blended biomass and fossil fuel briquettes	no	no									
Other blend of biomass and solid fuel	no	no									

Characteristics when operating with the preferred fuel only

Item	Symbol	Value	Unit	Item	Symbol	Value	Unit
Heat output				Useful efficiency (NCV as received)			
Nominal heat output	P_{nom}	6,7	kW	Useful efficiency at nominal heat output	$\eta_{th,nom}$	81,2	%
Minimum heat output (indicative)	P_{min}	n/a	kW	Useful efficiency at minimum heat output (indicative)	$\eta_{th,min}$	n/a	%
Auxiliary electricity consumption				Type of heat output/room temperature control (select one)			
At nominal heat output	e_{lmax}	-	kW	single stage heat output, no room temperature control		yes/no	
At minimum heat output	e_{lmin}	-	kW	two or more manual stages, no room temperature control		yes/no	
In standby mode	e_{lSB}	-	kW	with mechanic thermostat room temperature control		yes/no	
Permanent pilot flame power requirement				Other control options (multiple selections possible)			
Pilot flame power requirement (if applicable)	P_{pilot}	-	kW	room temperature control, with presence detection		yes/no	
				room temperature control, with open window detection		yes/no	
				with distance control option		yes/no	

Contact details/ Name and address of the manufacturer or its authorised representative.

DEFRO R. Dziubeła spółka komandytowa
26-067 Strawczyn
Ruda Strawczyńska 103A

Robert Dziubeła – president of the management board

PRODUCT SHEET

in accordance with the Commission Regulation no. 2015/1186
on the execution of the Directive of the European Parliament
and the Council 2010/30/EU and the Regulation 2017/1369

Name and address of the equipment supplier:

DEFRO R. Dziubela spółka komandytowa
26-067 Strawczyn
Ruda Strawczyńska 103A

Equipment parameters

Supplier's model identifier	DEFRO HOME ORION
Energy efficiency class	A+
Direct thermal output of the product	6.7 kW
Indirect thermal output	N/A
Energy efficiency Index	108
Performance at rated thermal output	81.2
Efficiency at minimal load	N/A
Special precautions	Consider guidelines included in the Service Manual delivered by the manufacturer each time before assembly, start-up or maintenance of the equipment

DEFRO
home 

DEFRO R. Dziubeła spółka komandytowa

26-067 Strawczyn
Ruda Strawczyńska 103A
tel.: 41 303 80 85
biuro@defro.pl
www.defrohome.pl

Infolinia serwisowa
509 702 720
509 577 900